

Oxford Bin Enclosure

EM206



EMERDYN

02 9534 1314

sales@emerdyn.com.au



Standard Specifications:

- Capacity: 120 litre
- Frame: SHS Steel
- Body: galvanised sheet steel
- Chute: stainless steel, 150mm diameter round aperture
- Fixings: stainless steel hinges & lock
- Finish: powder coated
- Fixture: inground with pins for chemsetting

Options:

- Capacity: 240 litre, twin units
- Body: stainless steel, customised
- Recycle: signage or colour coded finish
- Logo: template design required
- Decoration: circle, star & Logo (as per image below)
- Finish: 2 pac wet paint system
- Fixture: surface, sub-surface, inground with threaded rod for chemsetting

Option examples:



EM206-COS with decorative circle-star & City of Sydney logo option (custom logos available)



EM206 in Ironstone Satin powder coat

Oxford Bin Enclosure

EM206



EMERDYN

02 9534 1314

sales@emerdyn.com.au

Dimensions

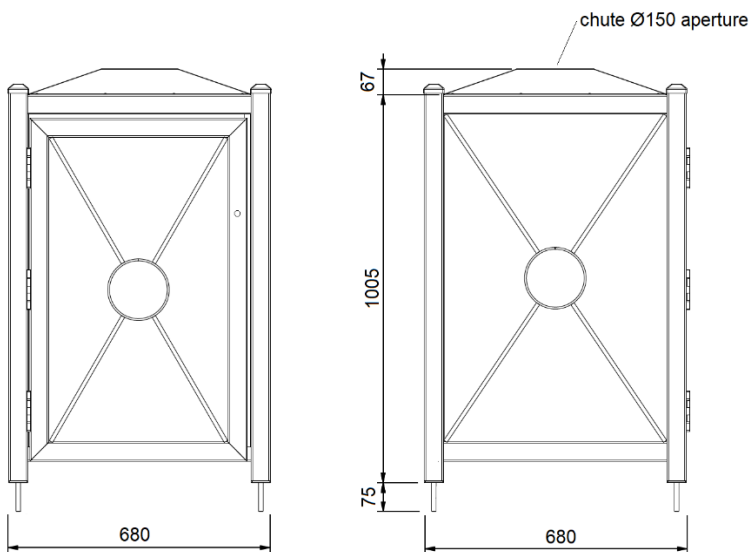

Internal clearance for 120L bin

- Height: 955
- Width: 561
- Depth: 605

Shown with threaded rod pins as standard fixing (for 120L), and decorative circle star custom option

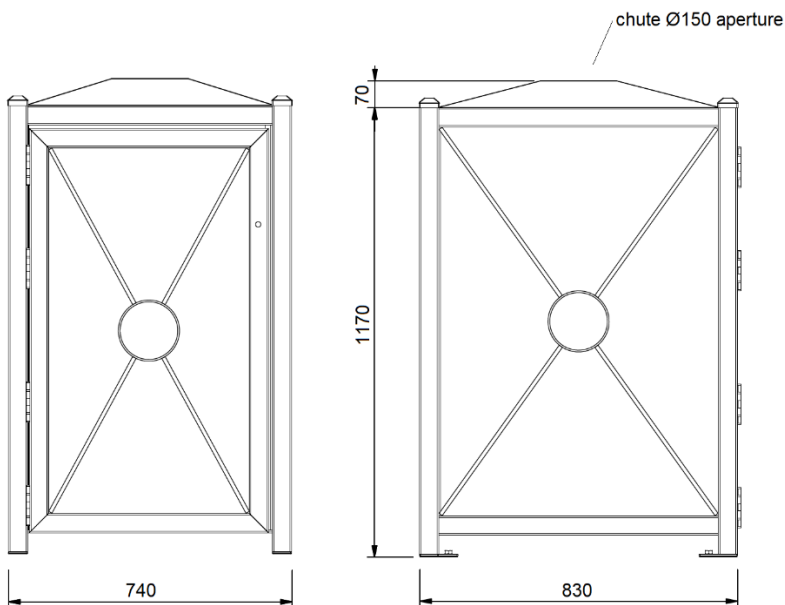

Internal clearance for 240L bin

- Height: 1120
- Width: 620
- Depth: 755

Shown with surface-mounted base plates as standard fixing (for 240L), and decorative circle star custom option